



DON'T MIND
IF I DO



July 7, 2023-January 7, 2024
Toby Devan Lewis Gallery
moCa Cleveland



● Lukaza Branfman-Verissimo

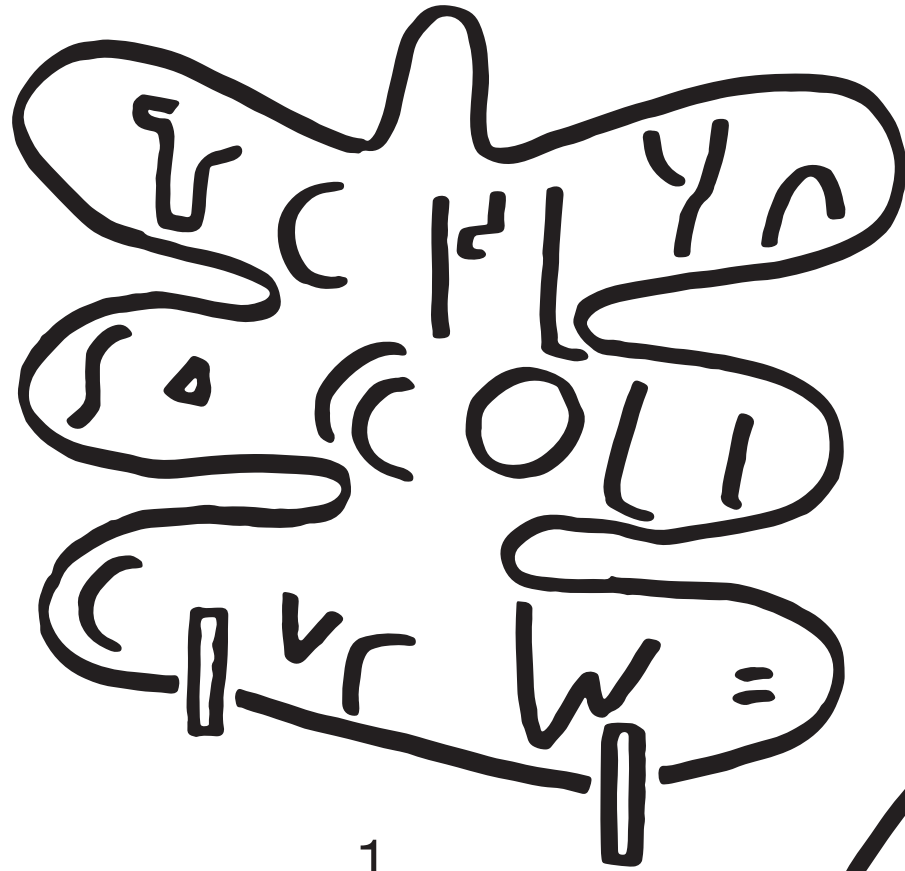

1. Lukaza Branfman-Verissimo
To Fly as a Collective We, in Rooted Ritual, 2023
Cardboard, acrylic paint

2.



2. Lukaza Branfman-Verissimo
Winged Survival, 2023
Cardboard, acrylic paint

WE ON OUR WAY WE WANT TO MEET YOU
WE DO WE LINKS IN A CHAIN WE
IF WE TO YOU, TO WE WE BEING
FROM US, TO YOU US, TO YOU
FROM US, TO YOU US, TO YOU
MIND DON'T MIND US, TO YOU
ENJOY US, TO YOU US, TO YOU
WE SIT & ENJOY US, TO YOU
ACCESS FANTASY WE SIT & ENJOY
WE LOOPING FROM US, TO YOU
FLOWING WE LOOPING FROM US, TO YOU
SILLY AND SERIOUS WE LOOPING FROM US, TO YOU

1.

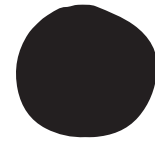

Lukaza Branfman-Verissimo & Finnegan Shannon

1. Lukaza Branfman-Verissimo
& Finnegan Shannon
We Hold Us, 2023
Chipboard, blue paint

● Pelenakeke Brown

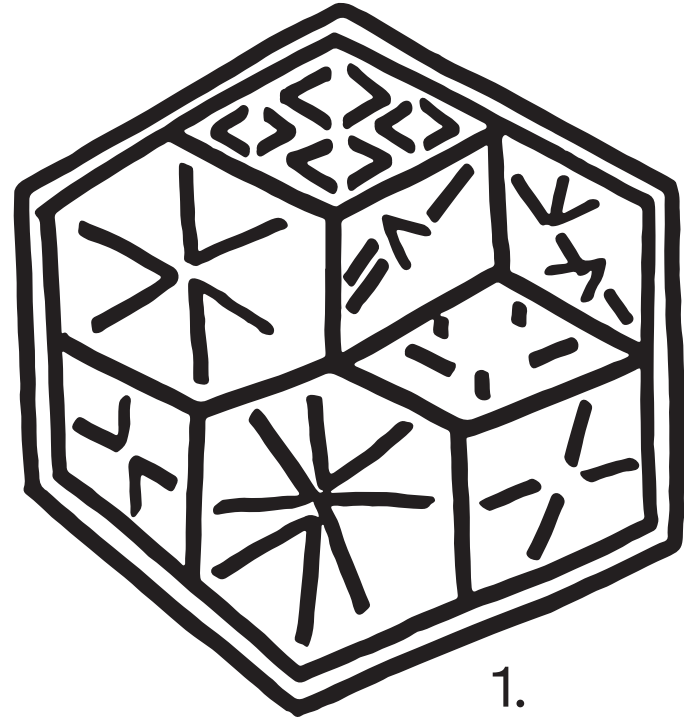

1.



2.

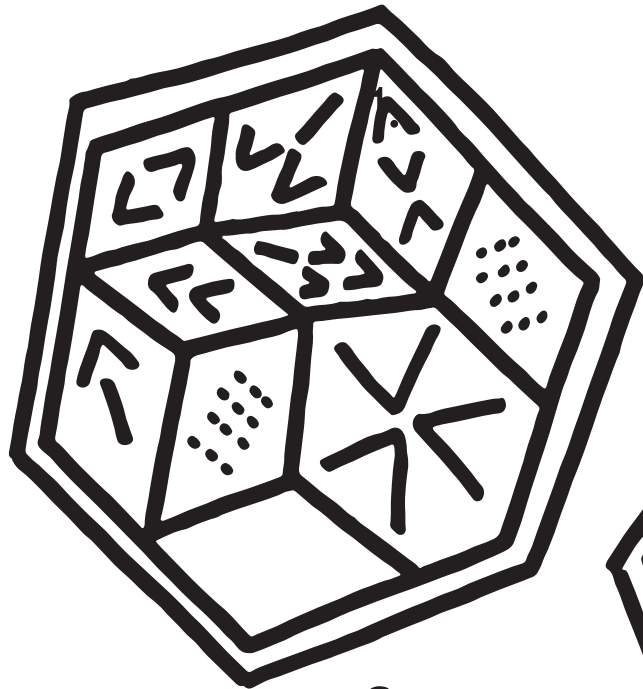

3.

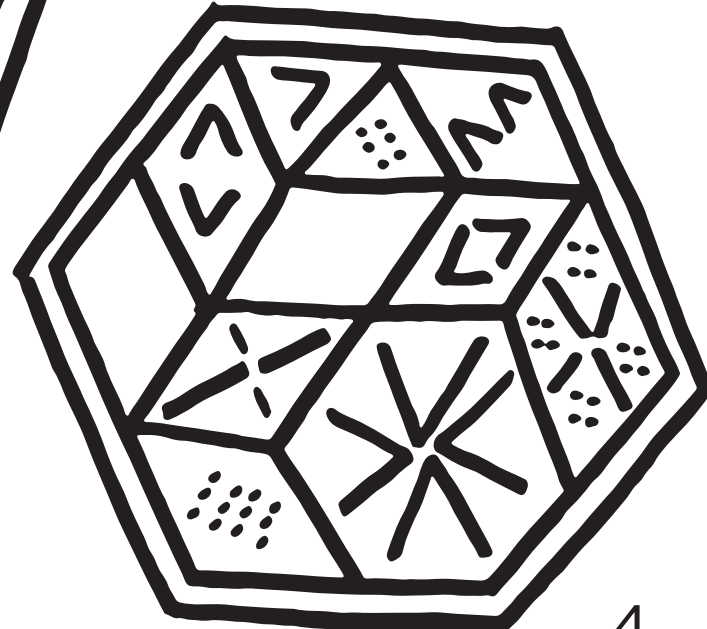

4.

1-2. Pelenakeke Brown, *Sit with Me*, 2023
Laser-cut plexiglass

3-4. Pelenakeke Brown, *Sit with Me*, 2023
Laser-cut wood

● Sky Cubacub

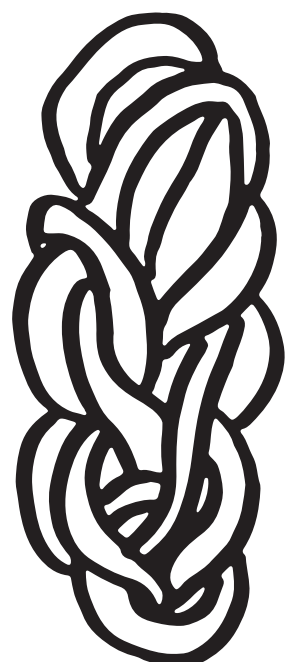

1.



2.

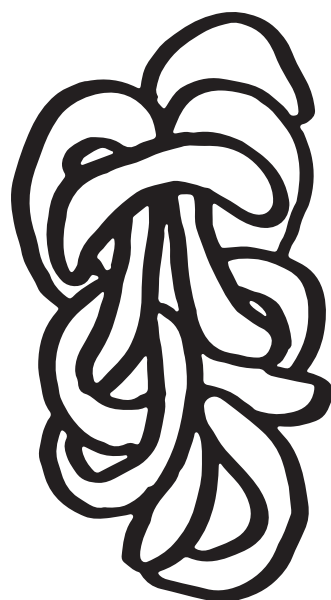

3.

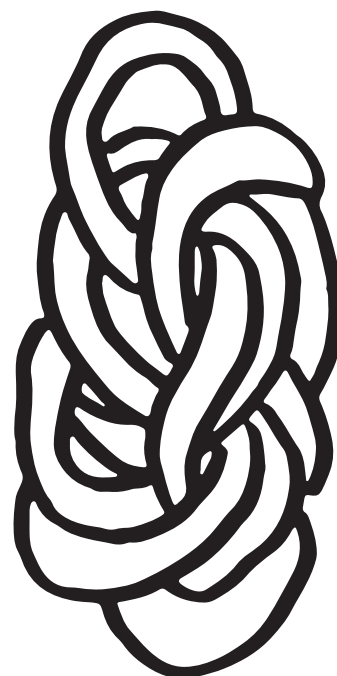

4.

1. Sky Cubacub
Black Chainmaille Packer, 2014
Chainmaille, Full Persian weave-anodized aluminum jump rings
2. Sky Cubacub
Lavender and Pink Chainmaille Packer, 2023
Chainmaille, Full Persian weave-anodized aluminum jump rings
3. Sky Cubacub
Turquoise Chainmaille Packer, 2023
Chainmaille, Full Persian weave-anodized aluminum jump rings
4. Sky Cubacub
Violet, Purple, and Gunmetal Chainmaille Packer, 2023
Chainmaille, Full Persian weave-anodized aluminum jump rings

All works courtesy of Rebirth Garments

● Emilie L. Gossiaux

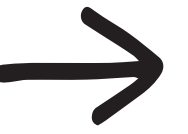

1.

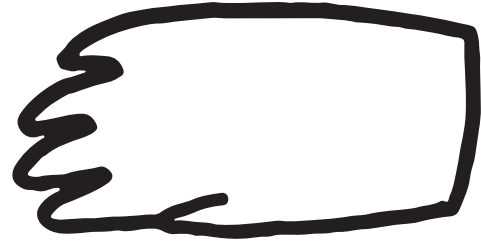

2.

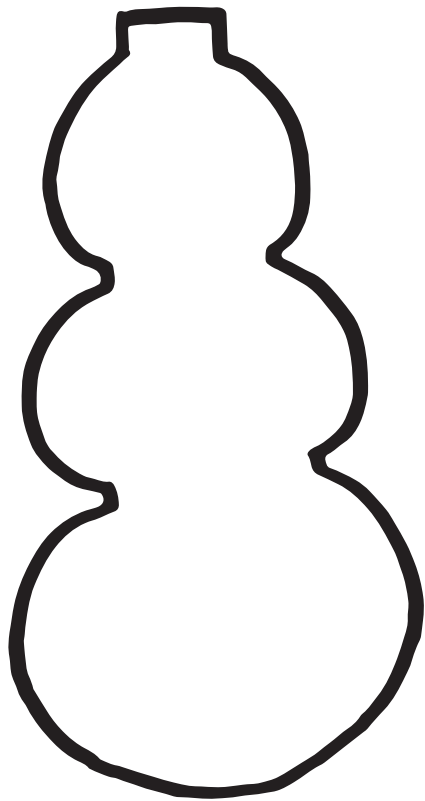

3.



4.

1. Emilie L. Gossiaux
Tongue and Paw, 2023
3d print, plastic
2. Emilie L. Gossiaux
Dog Paw on Foot, 2023
3d print, plastic
3. Emilie L. Gossiaux
Red Dog Kong, 2023
3d print, plastic
4. Emilie L. Gossiaux
Color Journal, 2023
Bound book

● Felicia Griffin

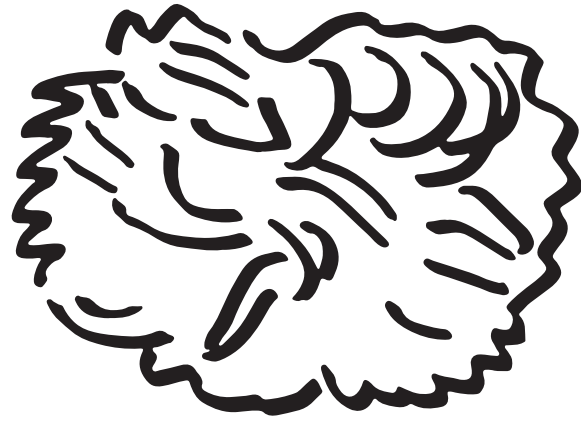

1.



2.



3.



4.



5.



6.



7.

1-7. Felicia Griffin
Pom-Pom, 2020
Yarn
Courtesy of the artist
and NIAD Art Center

● Joselia Rebekah Hughes →



1.

1. Joselia Rebekah Hughes
Verbena's Apothecary, 2021-ongoing
Mixed media

● Jeff Kasper



1.



4.



2.

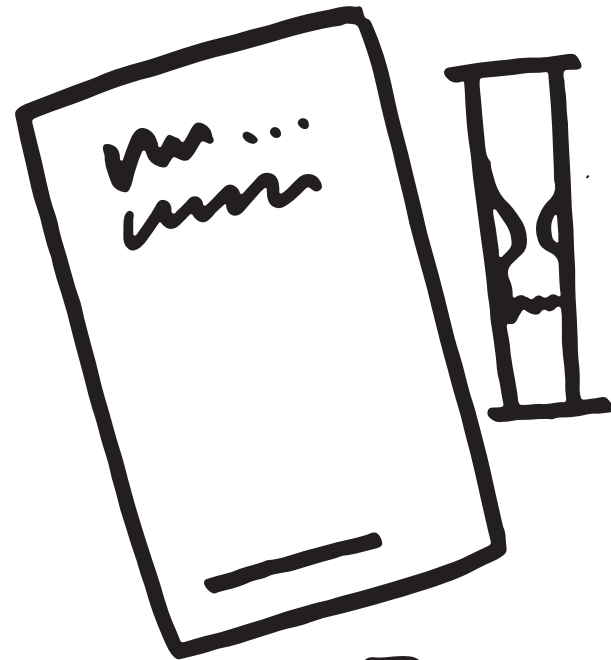

3.

- 1-3. Jeff Kasper
wresting embrace, 2023
Series of 40 playing cards featuring
contemplative and interactive prompts
for pairs
- 4. Jeff Kasper
*things remembered [I look fabulous
but I am in a lot of pain]*, 2023
Etched compact mirror in gold

● Finnegan Shannon

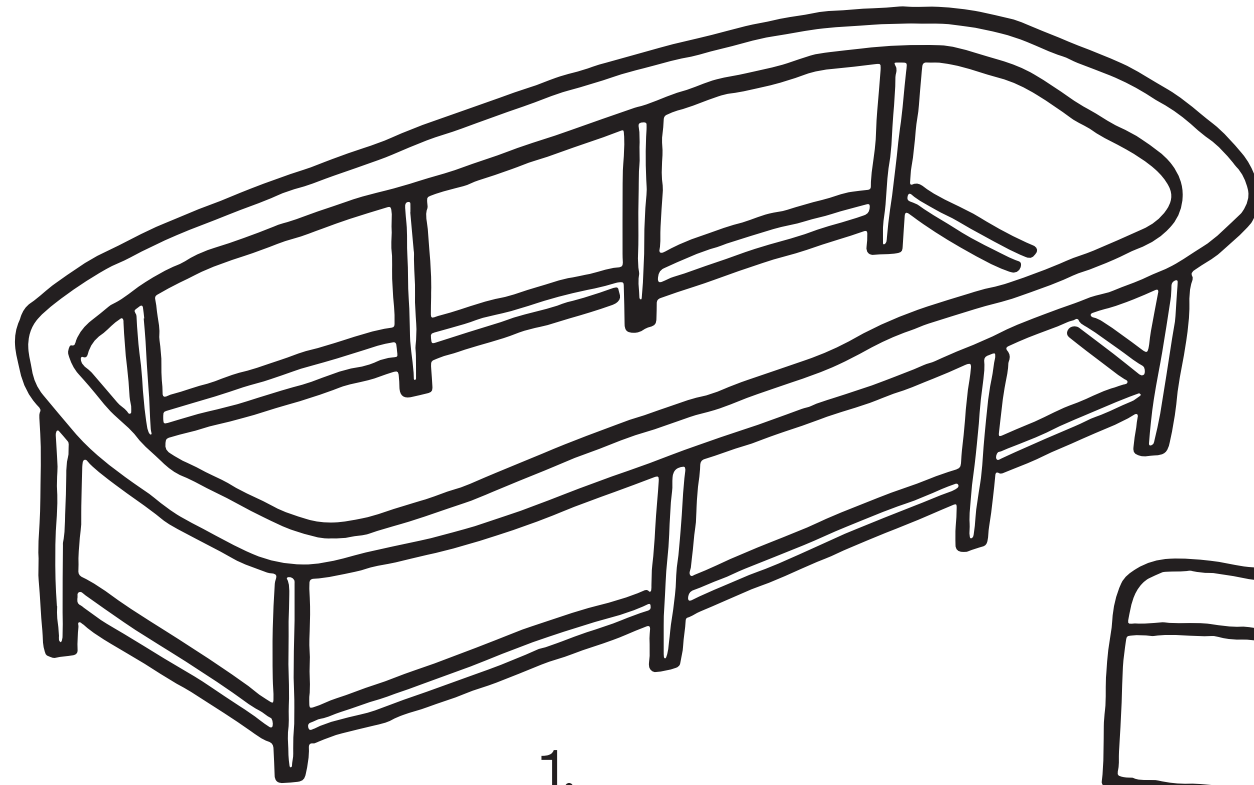

1.

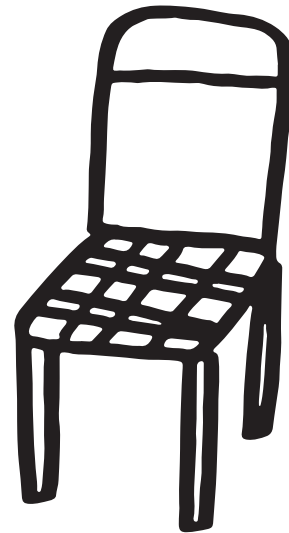

2.

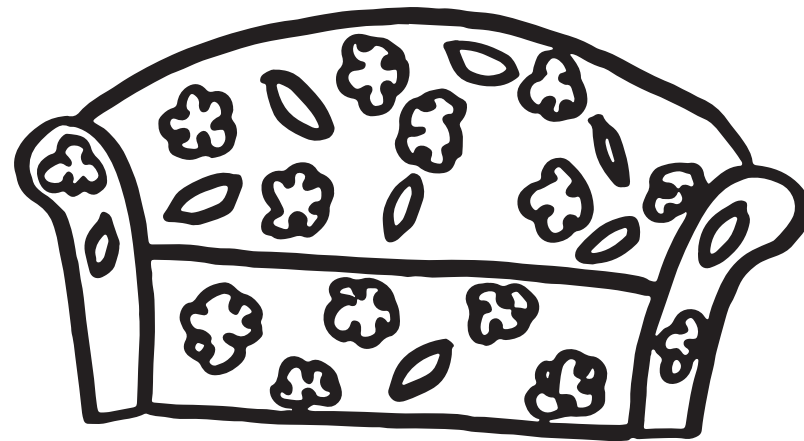
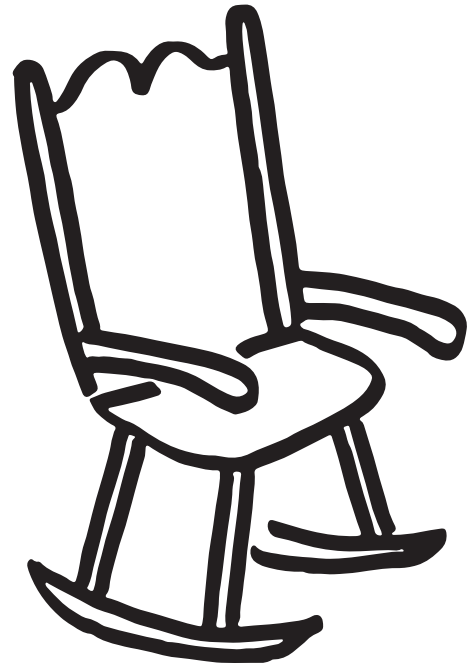

1. Finnegan Shannon
My access fantasy, 2023
Conveyor from 888 Brands Ltd,
modified by Peter Reese
and Finnegan Shannon
2. Finnegan Shannon
Variety/Comfort/Variety of Comforts, 2023
Secondhand furniture from
the Cleveland area



3.

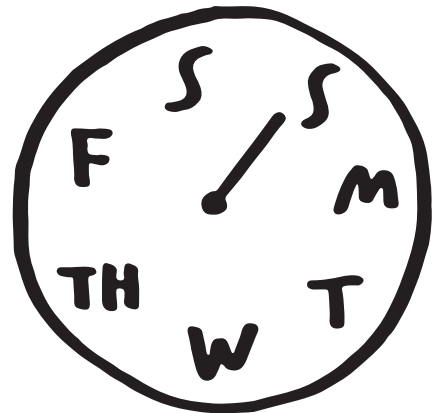

4.

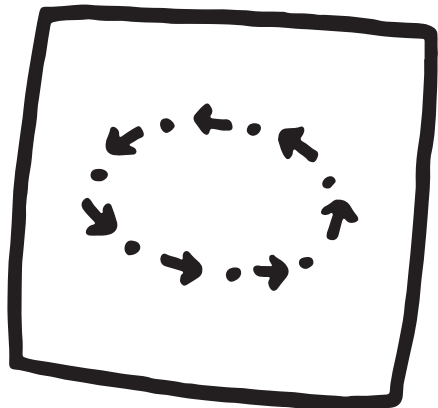

5.

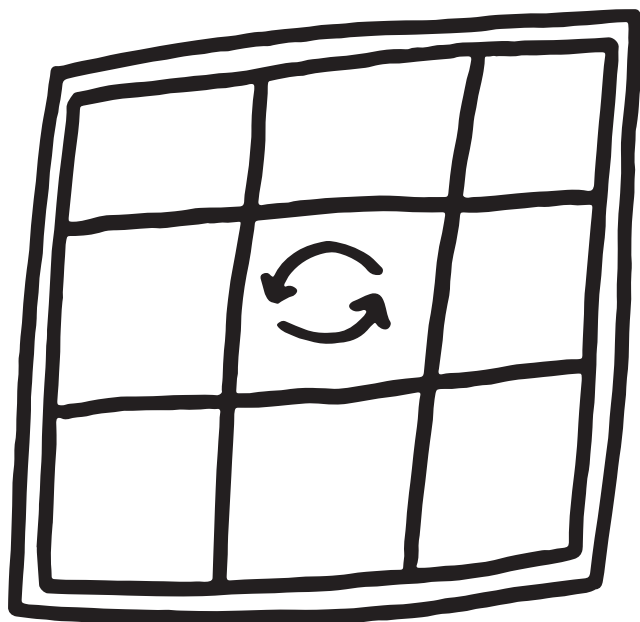

7.

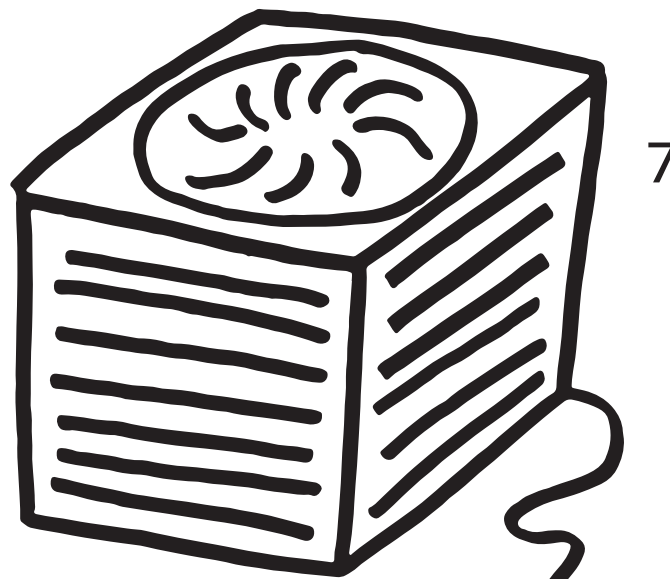

6.



3.

Finnegan Shannon
Slow Spin, 2023
7 Day Clocks; Day clock mechanisms,
dibond, clock hands, paint

4.

Finnegan Shannon
Softness for Don't mind if I do, 2023
13 cushions and pillows with
custom embroidery;
Sewn by Derya Hanife Altan

5.

Finnegan Shannon
Warmth for Don't mind if I do, 2023
Two throws; fabric, quilt batting,
custom embroidery

6.

Finnegan Shannon
Description for Don't mind if I do, 2023
Audio

7.

Finnegan Shannon
Air for Don't mind if I do, 2023
3 Corsi-Rosenthal Boxes

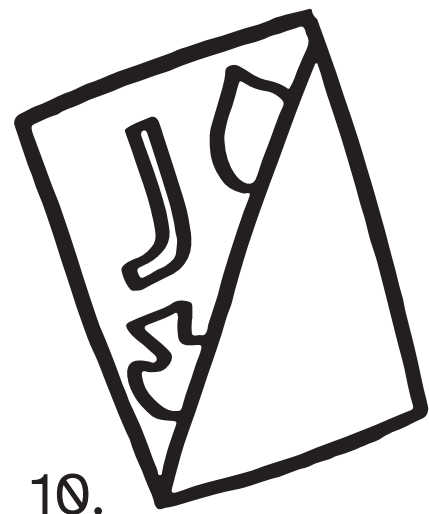
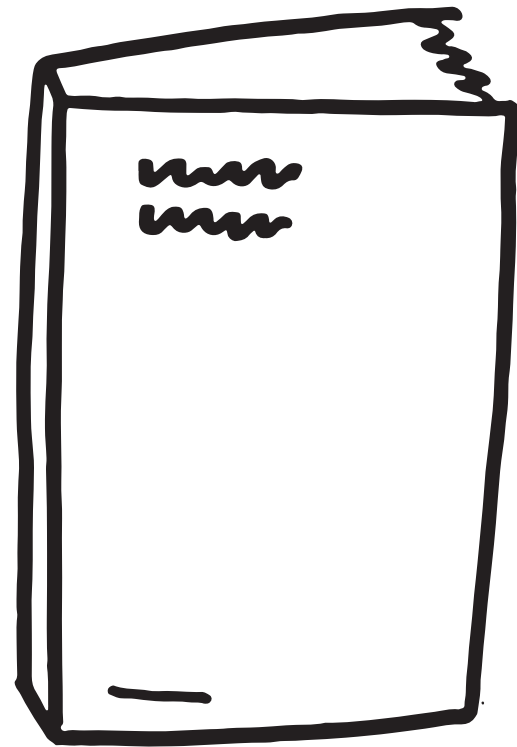
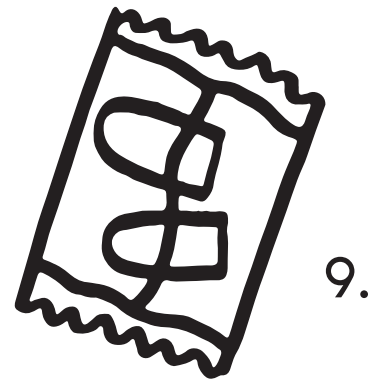
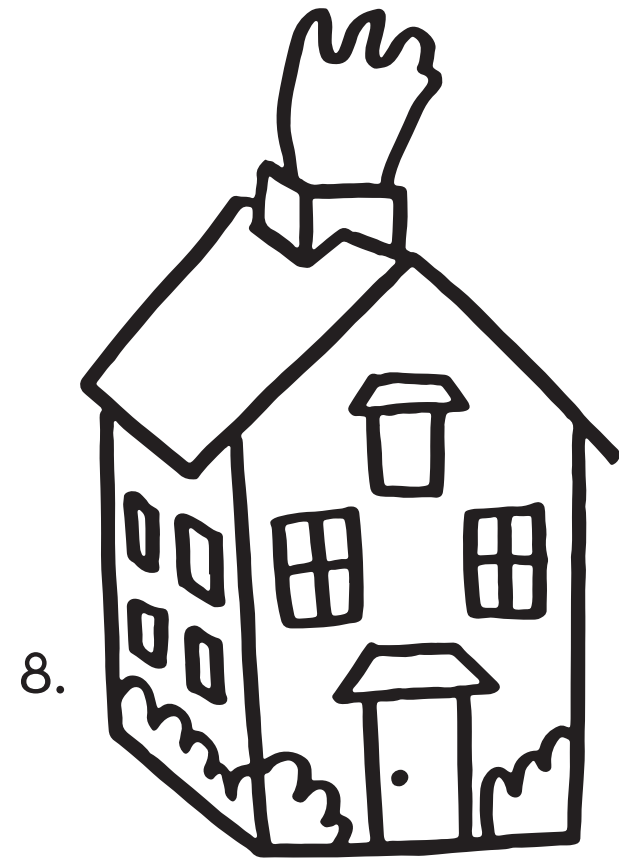
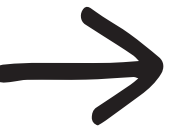

- 8. Finnegan Shannon
House that I modified to be stair-free and planted lavender in the garden for us, 2023
Modified vintage tissue box cover kit
- 9. Finnegan Shannon
Wow I wish the conveyor motor didn't make a sound
Earplugs
- 10. Finnegan Shannon
Extra play for Don't mind if I do
Large print playing cards
- 11. Finnegan Shannon
My favorite book, 2023
A Selection of Snapshots Taken by Felix Gonzalez-Torres
ISBN: 9787-0-923183-26-4

Don't mind if I do is organized by artist Finnegan Shannon with Curator Lauren Leving.

All current moCa Cleveland exhibitions are funded by leadership gifts from Doreen & Dick Cahoon, Joanne Cohen & Morris Wheeler, Margaret Cohen & Kevin Rahilly, Grosvie & Charlie Cooley, Becky Dunn, Harriet Goldberg, Agnes Gund, Jan Lewis, and Toby Devan Lewis*.



This zine is an artwork in this show!

Work info for Don't Mind if I Do
2023

Booklet

Made by Tom Poole
and Finnegan Shannon

Design by Tom Poole

Illustrations by Finnegan Shannon

Typeface is Atkinson Hyperlegible

moCa Cleveland receives institutional support in part by the residents of Cuyahoga County through a public grant from Cuyahoga Arts & Culture, the George Gund Foundation, the Nord Family Foundation, the Char & Chuck Fowler Family Foundation, the Leonard Krieger Fund of the Cleveland Foundation, the Ohio Arts Council, PNC, and the continuing support of the museum's Board of Directors, patrons, and members. FREE daily admission supported in part by the Connor Foundation. moCa's residency programs are sponsored in part by The Callahan Foundation.

*In memory